

HEMA

Recycling Container Handler 2 Tons

The HEMA Recycling Container Handler has been developed to handle the most common containers, equipped with 1 or 2 handling points.

The flexible setting of the open/close wire, allows it to be adapted to almost all recycling containers.

The MCT 35/60 can be delivered with a link for hooks, or for direct mounting on a rotator with a shaft.

It is a tool that facilitates and streamlines the handling of recycling containers, and is suitable for mounting on almost all types of auto cranes.

Mounted on a truck crane, one person can handle the recycling container, without having to get up or down from the truck bed, to hook on and off.

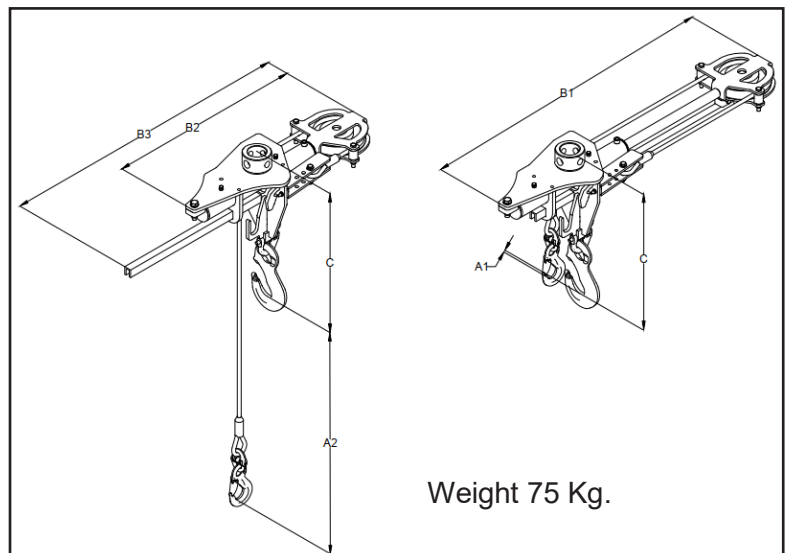

Product no.	Model	Max load Little hook	Max load Large hook	Max bar	Wire Pos.	A1 mm	A2 mm	B1 mm	B2 mm	B3 mm	C mm
3055 4200	MCT 35/60	2 Tons	2 Tons	200	1	- 76	874	1187	864	1176	605
					2	- 38	912				
					3	0	950				