

## UHL2705

Crane mounted Tyre handler

This tyre handler can be fitted to most lorry mounted cranes having a minimum capacity of 13 tonne metres.

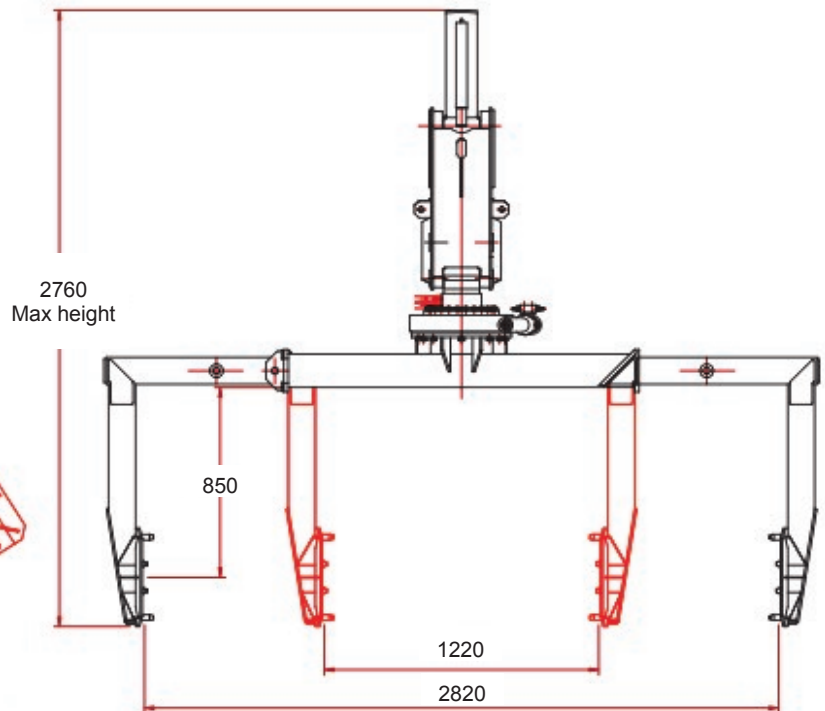
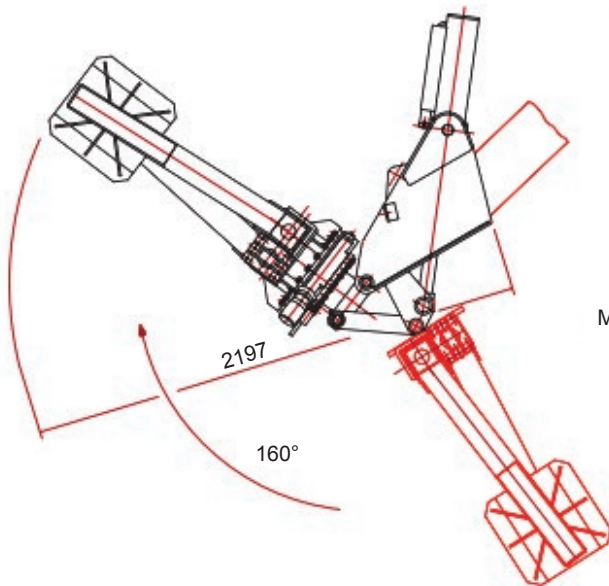

### Operation

Model UHL2705 requires three separate services at the jib, with respective operating levers at the crane base. This model achieves all motions, i.e. tilt, clamp and rotate totally independent of the actual crane operation.

Note. Customer to supply manual stub boom 1.5 metre minimum.

### Technical Specifications.

Operating range	Min.	1220mm.
	Max.	2700mm.
Tyre size handled	Min.	17.50 x 25
	Max.	27.00 x 49
Safe working load		2.5 Tonnes.
Rotation		360°
Rotation Speed		5.5 RPM Maximum
Tilt angle		160°
Working pressure	Min.	180 Bar.
	Max.	250 Bar.
Clamping method		Horizontal Telescopic
Clamping lock		Pilot operated Check valve
Handler tilt		Integral tilt ram c/w hose burst valve
Weight of Handler		750 Kg.
Recommended Crane minimum		13 Tonne metre

