

# HEMA

## Barrier Lifter

HEMA Barrier Lifters facilitate and streamline work with the vast majority of concrete barriers in an easy and safe manner.

Type PZM-NJ for mechanical handling of barriers.  
Lifting eye for hook.  
Rubber jaws for protection of the concrete barriers.  
Steel jaws by request.



Steel Jaws  
Extra accessory

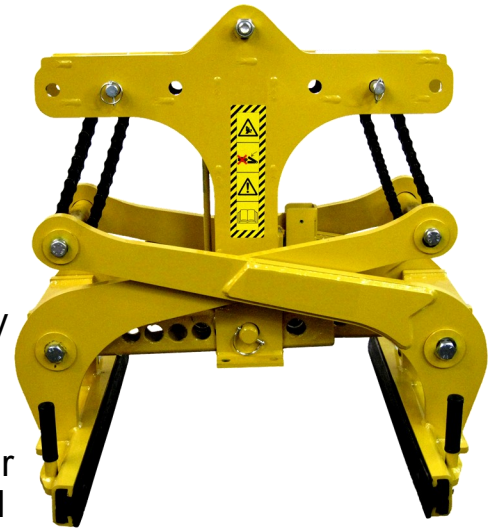

Barrier Lifter  
Mechanical  
PZM-NJ

Product no.	TYPE	Opening meas. mm	SWL kg	Weight kg
HSK000273	PZM NJ	50 - 850	5000	235

Type V2 with width adjustable lifting hooks, making it possible to handle the most common barrier types.

The V2 barrier grapple is designed for barriers with a center distance between the lifting eyes of 225 mm to 1030 mm

Max. 1000 kg. SWL.



Barrier Lifter  
V2 225 - 1030

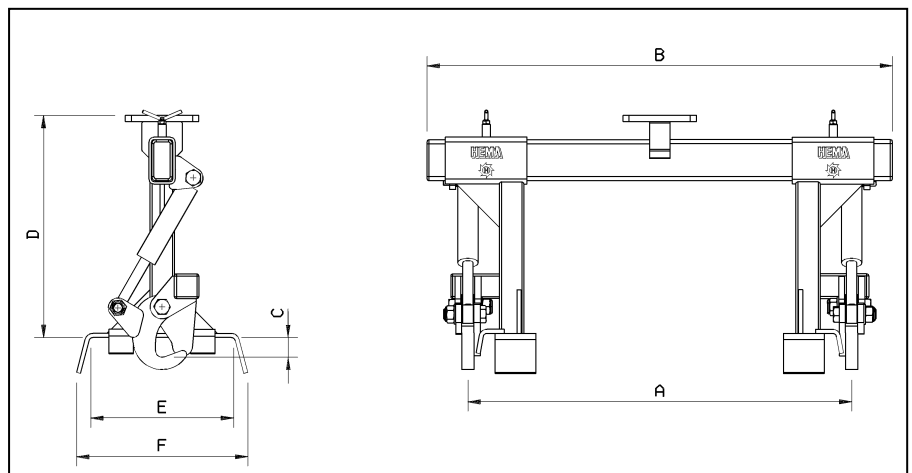

Product no.	TYPE	Bar	Max load Kg.	A mm	B mm	C mm	D mm	E mm	F mm	Weight kg
3050 1185	Barrier Lifter V2 225-1030	200	1000	225 - 1030	1140	48	540	350	419	85

Subject to print errors and changes 2011.11.10