

# HEMA

## Spaghnum grapple Type 2 CV 50-80

HEMA Spaghnum grapple is designed for a working pressure of 170 - 200 bar, making it applicable to almost all types of auto cranes.

The Spaghnum grapple can also be used for chips, sawdust and waste and one of its features is the special blades that easily breaks the often difficult and compact mass.

The Spaghnum grapple can also be delivered with standard blades at the bottom, to protect the base.

The grapple can be delivered with closed or semiclosed shells, different designs of the side and bottom blades, such as saw teeth or special teeth.

The HEMA grapple opens up so the blades are fully vertical, making it easier to grab the mass.

All moving parts are equipped with efficient lubrication and replaceable bearings, making possible repair easy, fast and affordable.

The grapple is delivered with individual adjustment of boltmounted link for the rotator with shaft.



## Spaghnum Grapple SP 2 CV 50-80-1500

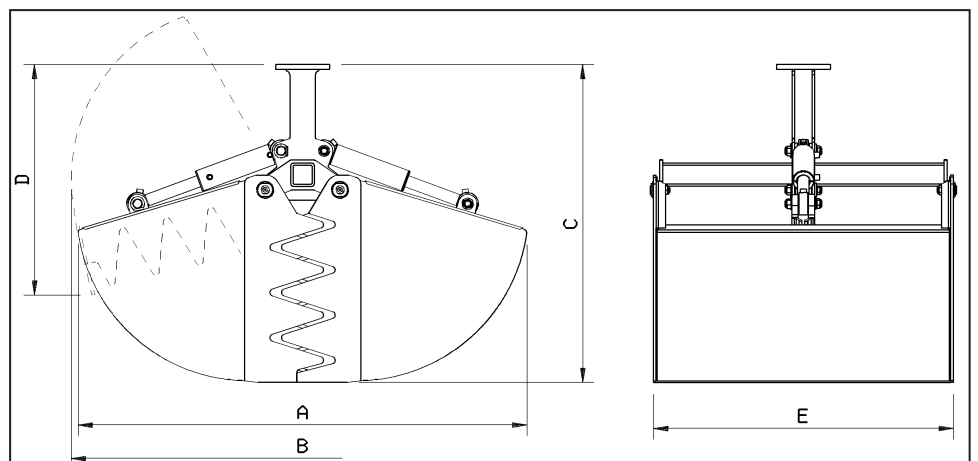

Product no.	TYPE	Bar	Contents	A mm	B mm	C mm	D mm	E mm	Weight kg
3030 5420	SP 2 CV 50-80 1000	200	1000 L	1690	1770	1175	750	1260	470
3030 5440	SP 2 CV 50-80 1500	200	1500 L	1920	1980	1360	980	1280	520

Subject to print errors & changes. 2011.10.26