

# HEMA

## Sugarbeet Basket Type RK50-90

The Sugarbeet Basket is designed for a working pressure of 170 - 200 bar, making it applicable to almost all types of cranes.

Max. pressure 200 bar.

The horizontal and well-protected cylinder provides extra low construction height, high closing force and quick opening time of the basket.

The cylinder is adjustable for compensation of wear.

The fastening method of the grapple's base makes changing these easy and effortless without the need for special tools.

Individual adjustment of link.

As a special model, the basket can be delivered with closed shells, as well as welded blades for handling crops and similar materials.



**HEMA Sugarbeet Basket  
RK90-1250**



**HEMA Sugarbeet Basket  
RK90-2500**

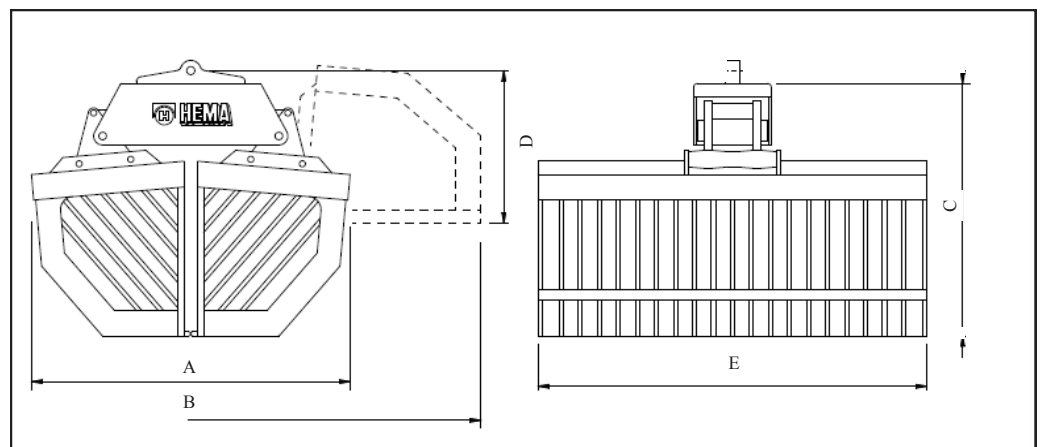

Product no.	TYPE	Bar	Contents	A mm	B mm	C mm	D mm	E mm	Weight kg
3015 5350	RK90-1250	200	1250 L	1200	2410	1075	630	1500	450
3020 5330	*RK90-2000-2	200	2000 L	1600	2580	1160	630	1790	800
3020 5340	*RK90-2500-2	200	2500 L	1600	2580	1160	630	2195	1000

\* Over 1500 L = 2 hydraulic units.



**HEMA**

K.S.M. Kragelund ApS.  
Bøgballevej 19, Kragelund, DK-8723 Løsning  
Tlf. + 45 75893711 - Fax. + 45 75893709  
Mail: hema@ksm-hema.dk / www.hema.world

Manufacturing and sales of  
HEMA Crane Equipment  
and Mudguards

