

HEMA

Wood Chip Grapple S- series

The wood chip grapple is designed for a working pressure of 200-350 bar, making it applicable to almost all types of cranes and excavators.

The S-series is HEMA's new grapple designed for truck operators and contractors.

The series is designed to be used where demands are placed on the grapple's strength in terms of when grabbing wood chips, sawdust, sphagnum or similar materials.

The special blades, help break through the compact mass easier.

The HEMA grapple opens so that the blades are vertical, allowing you to grab all the way out to the sides.

The main bolts are spread wide apart to achieve good stability between the grab shells.

The s-series has powerful bolts and bushings in all of its moving points causing durability and longevity.

The s-series are delivered with adjustable cylinders as in previous models, with the possibility to compensate for any possible wear in the future.

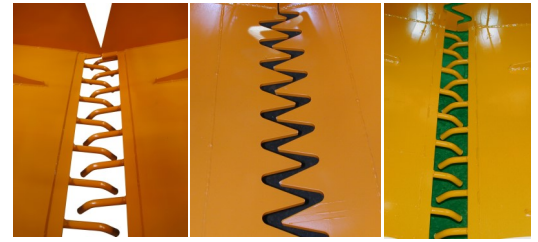

Blades are constructed to easily break the often compact mass.

Wood Chip Grapple
FGS 90-1500
with std. bottom blades
and special opening



Wood Chip Grapple
FGS 90-1500 with
wood-chip teeth



FGS90-1120UO

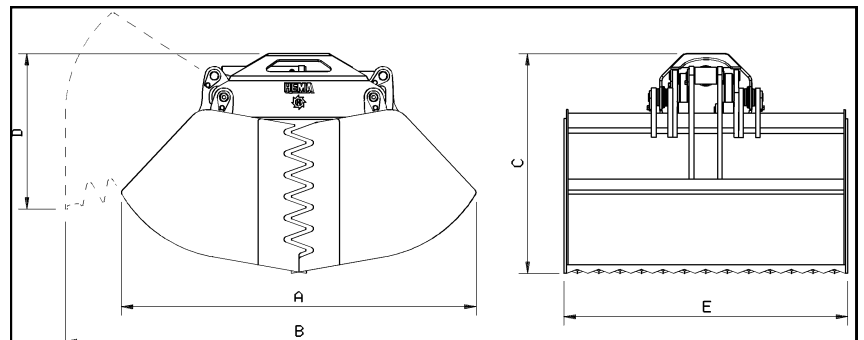

Product no.	TYPE S- series	Bar	Contents L	A mm	B mm	C mm	D mm	E mm	Weight kg
	FGS 90-1200	200/350	1200	1750	2300	1070	810	1516	710
3016 5430	FGS 90-1500	200/350	1500	1900	2500	1170	830	1516	766
3016 5432	FGS 90-1500 ST	200/350	1500	1900	2500	1170	830	1516	766
	FGS 90-2000-2	200/350	2000	1894	2440	1129	830	2020	1200
3016 5450	FGS90-1120UO	200/350	1120	1129	2416	1102	879	1500	720



HEMA

K.S.M. Kragelund ApS.
Bøgballevej 19, Kragelund, DK-8723 Løsning
Tlf. + 45 75893711 - Fax. + 45 75893709
Mail: hema@ksm-hema.dk / www.hema.world

Manufacturing and sales of
HEMA Crane Equipment
and Mudguards

