

HEMA

Waste Grapple - S- series

The waste grapples are designed for a working pressure of 200-350 bar, making them applicable for almost all types of cranes and excavators.

The S-series is HEMA's strong grapple for truck cranes and contractors, designed for applications where there are high demands for grapple strength.

The S-waste grapple is used for handling bulky waste and branch waste.

The S-series is equipped with very powerful bolts and bushings at all moving points, which entails high wearability and durability.

The main bolts are spaced wide apart to achieve great stability between the grapple and the grapple shells.

The S-series comes with a pressure reduction valve and a 200 bar cylinder that is adjustable in stroke length as in previous models, with the ability to compensate for any potential wear.

The S-waste can be delivered with other shell dimensions.



**HEMA Waste Grapple
AGS90-800**



S-series Lifting Hooks

The S-series can now be delivered with boltable lifting hooks mounted on each side of the top. This enables easy lifting of machines and other materials.

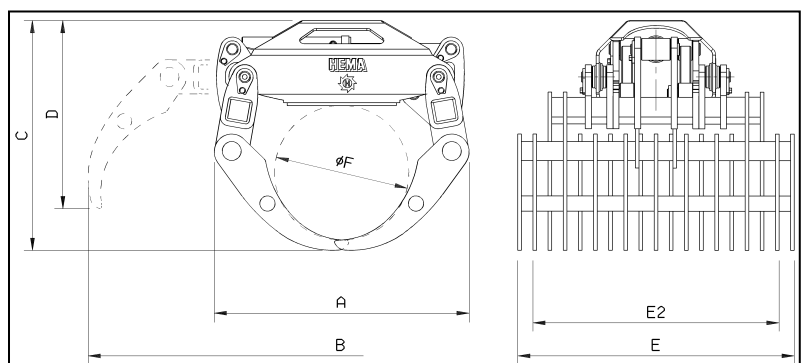

Product nr.	TYPE S- serien	Bar	Contents	A mm	B mm	C mm	D mm	E mm	E2 mm	øF mm	Weight kg
3016 5545	AGS 90-800 M2	350 / 200	375 L*	1050	2090	945	775	1140	1015	555	465

*At 500 mm open, the contents are 675 liters.