

HEMA

Soil Grapple Type HJ50-90

The soil grapple is designed for a working pressure of 170-200 bar, making them applicable to almost all types of cranes.

The horizontal and well-protected cylinder provides an extra low construction height, big closing force and quick opening time.

The HEMA grapple opens up so that the blades are vertical, enabling the grapple to grab all the way to the car's sides.

The grapple is delivered in designs that have a larger volume designed for handling of lighter materials such as, mussels, leca and sawdust, etc.

The grapple is delivered with individual adjustment of bolt-mounted link for a rotator with a shaft.



**HEMA Soil Grapple
HJ90-500**



All moving points are equipped with lubrication and replaceable bearings, which will make any potential repair easy, fast and affordable.

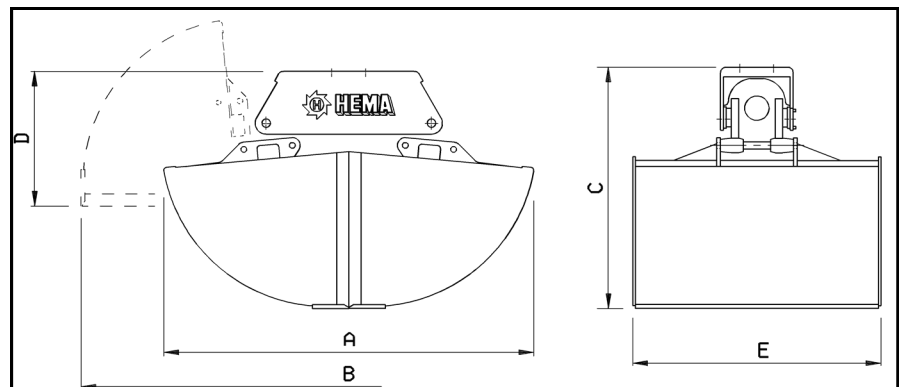

Product nr.	TYPE	Bar	Contents	A mm	B mm	C mm	D mm	E mm	Weight kg
3015 5020	HJ90-350	200	350 L	1516	2220	975	550	545	340
3015 5025	HJ90-500	200	500 L	1516	2220	975	550	795	370
3015 5030	HJ90-700	200	700 L	1516	2220	975	550	1045	415
3015 5033 *	HJ90-860 LET	200	860 L	1520	2200	975	550	1278	455
3015 5035 *	HJ90-1000 LET	200	1000 L	1520	2200	975	550	1450	485
3015 5040 *	HJ90-1200 LET	200	1200 L	1656	2340	1035	550	1450	535
3015 5050 *	HJ90-1500 LET	200	1500 L	1830	2510	1150	630	1476	555

* Special products - manufactured after order.



HEMA
K.S.M. Kragelund ApS.
Bøgballevej 19, Kragelund, DK-8723 Løsning
Tel. + 45 75893711 - Fax. + 45 75893709
hema@ksm-hema.dk / www.hema.world

Manufacturing and sales of
HEMA Crane Equipment,
and mudguards

